

Ø 5" - Ø 14" Large Bore Cylinders

- Built for heavy duty and demanding applications with steel tube and cast iron end cover construction.
- Options like viton seals, leather bellows, High temp. bellows, S.S. piston rod and 'Rod eye end' can be offered as per customer requirements.
- Different special cylinders like double ended, single acting, or adjustable stroke construction are also offered.

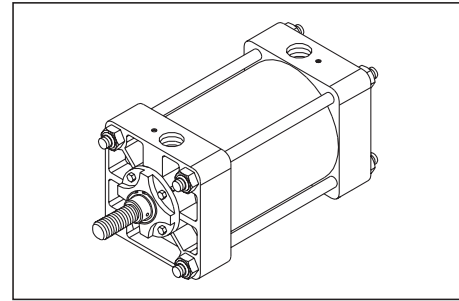

PART LIST

NO.	DESCRIPTION	QTY.
1	Front cover	1
2	Rear cover	1
3	'O' ring for cover	2
4	Tube	1
5	Wiper seal	1
6	Circlip	1
7	Wiper seal housing	1
8	'U' cup seal	1
9	'O' ring	1
10	Piston	1
11	Wear ring	1
12	'U' cup for piston	2
13	Spacer for piston	2
14	Washer for piston	2
15	Spring washer	1
16	Nut	1
17	Screw for piston	8
18	Piston rod	1
19	Piston rod bush	1
20	Hex. screw with spring washer	4
21	Nylock nut	8
22	Tie rod	4
23	Allen screw with washer	1
24	'O' ring (Bleed screw)	2
25	Retaining clip	2
26	'O' ring for piston	1
27	Cushioning 'U' cup	2
28	Pin	2
29	Steel ball	2
30	Bush bearing	1
31	Bearing housing	1
32	Bleed screw	2
33	Lock screw	2
34	Lock nut	1

Seal kit consists of items 3, 5, 8, 9, 11, 12, 24, 26 & 27.

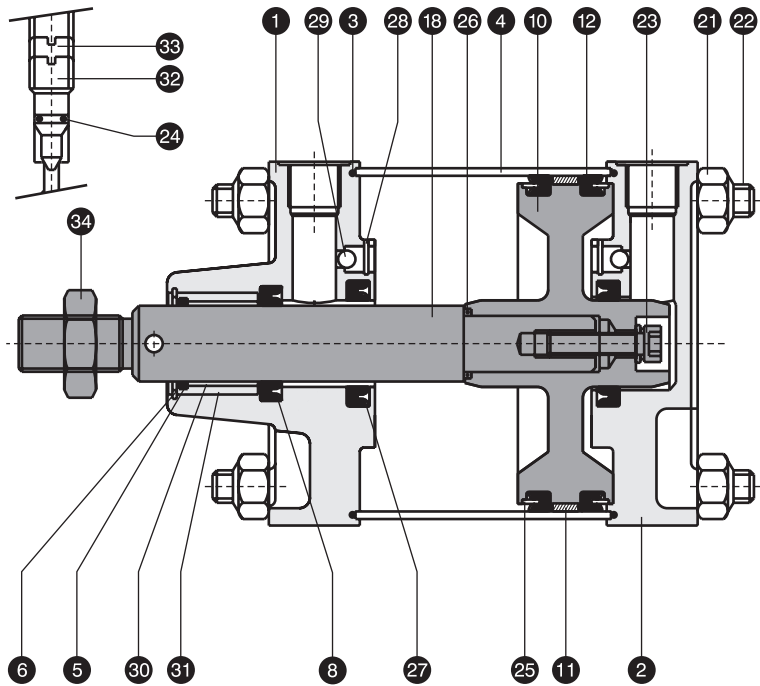

Ø 5" & Ø 6" Cylinder

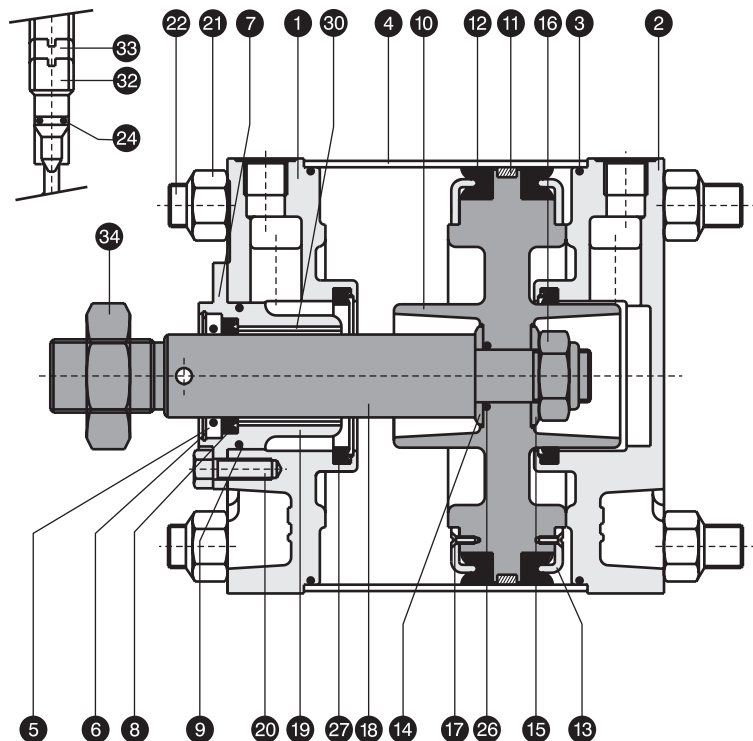

Ø 8", 10", 12" & 14" Cylinder

SPECIFICATIONS

Medium	Compressed air, Filtered
Design	Pneumatic piston cylinder with adjustable cushioning at both ends
Max. operating pressure	10 bar
Temperature range	-10° C to 85° C (180° C for viton seals)
Material	a) End Covers : Cast iron b) Piston Rod : EN8 Hard chrome plated (Stainless steel optional) c) Cylinder barrel : Steel / Aluminium d) Seals : NBR (Viton optional)

BASIC CYLINDER DIMENSIONS

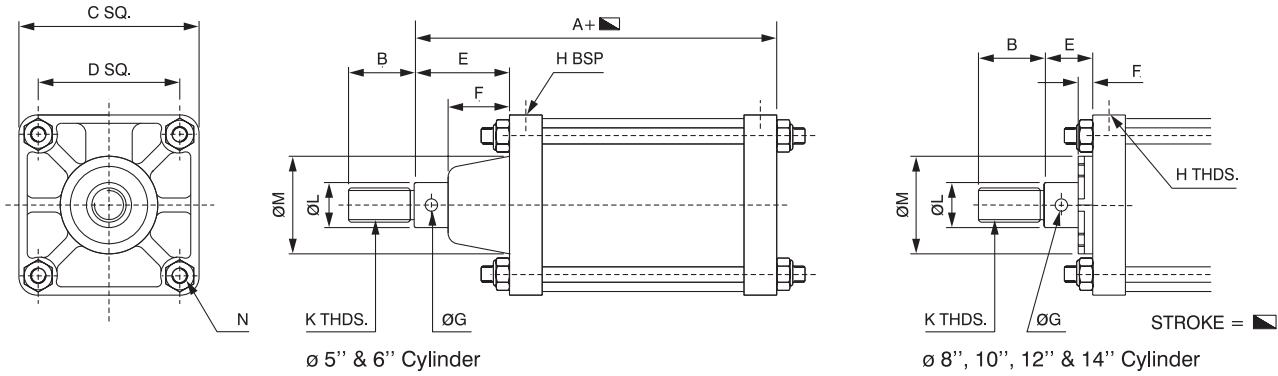

BORE SIZE MM (INCH)	A	B	C	D	E mm	F mm	ØG	H BSP	K BSF	K * METRIC ALTERNATE	Ø L	Ø M	N BSF
127 (5")	167	51	140	108	65	48	8	G 3/8	1" - 10	M 27 X 2	35	70	1/2" - 16
152 (6")	184	51	165	130	63	46	8	G 3/4	1" - 10	M 27 X 2	35	80	5/8" - 14
203 (8")	205	57	216	168	29	16	8	G 3/4	1-1/2" - 8	M 36 X 2	45	121	3/4" - 12
254 (10")	240	76	267	210	43	17	9	G 3/4	2" - 7	M 48 X 2	57	150	1" - 10
304 (12")	286	76	321	246	60	28	9	G 1	2" - 7	M 48 X 2	57	196	1" - 10
355 (14")	286	76	375	292	60	28	9	G 1	2" - 7	M 48 X 2	57	196	1-1/4" - 9

*Cylinder is offered with BSF threading as standard. For metric threadings on piston rod as per 'alternate' please specify while ordering.

PISTON THRUST CHART (Theoretical)

BORE SIZE	PR. Dia		AIR PRESSURE (BAR)										FREE AIR CONSUMPTION IN ϕ 25mm STROKE @ 7 BAR PR.
			1	2	3	4	5	6	7	8	9	10	
			THRUST AVAILABLE (KGF)										
127 (5")	35	PUSH	126	253	380	506	633	759	886	1013	1139	1266	2.5
		PULL	117	234	351	468	585	702	819	936	1053	1170	2.3
152 (6")	35	PUSH	182	364	547	729	911	1094	1276	1458	1641	1823	3.7
		PULL	172	345	518	691	863	1036	1209	1381	1554	1727	3.5
203 (8")	45	PUSH	324	648	972	1296	1620	1944	2269	2593	2917	3241	6.5
		PULL	308	616	924	1233	1541	1849	2157	2466	2774	3082	6.2
254 (10")	57	PUSH	506	1013	1519	2025	2532	3038	3545	4051	4558	5064	10.1
		PULL	481	962	1442	1923	2404	2885	3366	3847	4328	4809	9.6
304 (12")	57	PUSH	729	1458	2188	2911	3646	4375	5105	5834	6563	7293	14.5
		PULL	703	1407	2117	2815	3519	4222	4926	5630	6334	7038	14.0
355 (14")	57	PUSH	992	1985	2978	3970	4963	5956	6948	7941	8933	9926	19.8
		PULL	967	1934	2901	3868	4835	5803	6768	7737	8704	9671	19.2

NOTE : To decide cylinder bore size : ● Establish force required and working pressure available. ● Select working pressure on top of the chart. ● Select force required by reading down from selected working pressure. ● Read out cylinder bore size on left of the chart. ● For all practical purposes it is advisable to consider 20% extra force while establishing force required.

EXAMPLE : If it is established that the force required is 1100 Kg. and working pressure available is 7 bar, above chart will lead you to select 6" bore cylinder.

DOUBLE TRUNNION MOUNTING

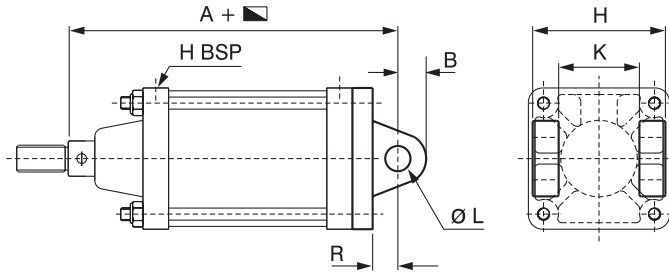

CYLINDER BORE	MTG. PART NO.	A mm	B mm	H mm	K mm	ØL mm	R mm
127 (5")	5001	211	25	139.7	88.9	25.4	25
152 (6")	6001	235	25	171.5	108.0	25.4	29
203 (8")	8001	263	41	222.3	146.0	38.1	29
254 (10")	A001	304	44	269.9	165.1	38.1	32
304 (12")	A201	369	50.8	327	200	38.1	50.8
355 (14")	A401	381	57.2	381	228.6	57.1	63.5

REAR PLATE MOUNTING

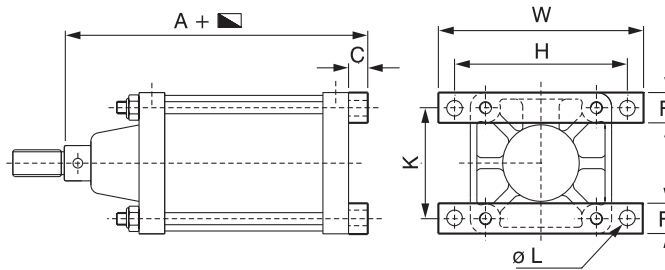

CYLINDER BORE	MTG. PART NO.	A mm	C mm	F mm	H mm	K mm	ØL mm	W mm
127 (5")	5003	186	19	38.1	171.5	108	13.5	203
152 (6")	6003	203	19	38.1	203.2	130.2	16.5	242
203 (8")	8003	230	25	51	266.7	168.3	20	318
254 (10")	A003	272	32	57	311.2	209.5	26	362
304 (12")	A203	318	32	63.5	384.2	246	27	448
355 (14")	A403	324	38	76.2	457.2	292	33.4	533

SINGLE TRUNNION MOUNTING

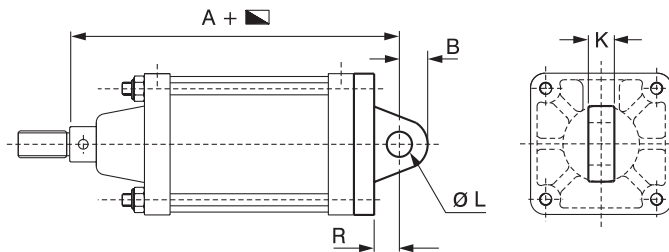

CYLINDER BORE	MTG. PART NO.	A mm	B mm	K mm	ØL mm	R mm
127 (5")	5009	238	25.4	56	25.4	44
152 (6")	6009	254	35.0	57	25.4	43
203 (8")	8009	280	41	67	38.1	48
254 (10")	A009	319	38	70	38.1	49
304 (12")	A209	382	41	102	38.1	57
355 (14")	A409	407	54	127	57.15	98

CENTRE TRUNNION MOUNTING

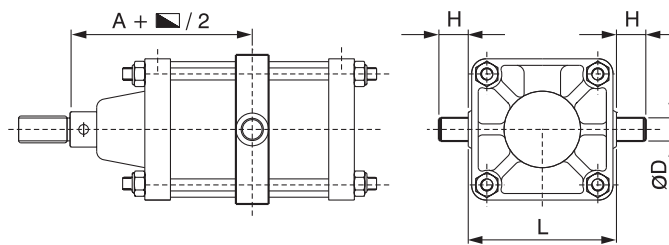

CYLINDER BORE	MTG. PART NO.	A mm	ØD mm	H mm	L mm
127 (5")	5005	116	38.1	51	159
152 (6")	6005	124	38.1	45	191
203 (8")	8005	117	44.4	54	248
254 (10")	A005	141	50.8	64	305
304 (12")	A205	173	76.2	76	381
355 (14")	A405	173	88.9	102	457

LEG MOUNTING

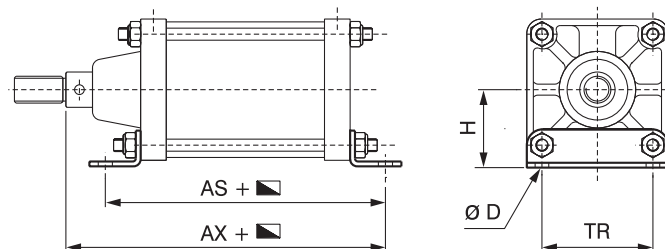

CYLINDER BORE	MTG. PART NO.	ØD mm	H mm	AS mm	AX mm	TR mm
127 (5")	5007	13	89	172	202	108.0
152 (6")	6007	17	89	211	229	130.2
203 (8")	8007	19	122	252	244	88.9
254 (10")	A007	26	149	286	285	114.3
304 (12")	A207	27	178	328	337	139.7
304 (14")	A407	33	213	359	352	158.8

FRONT PLATE MOUNTING

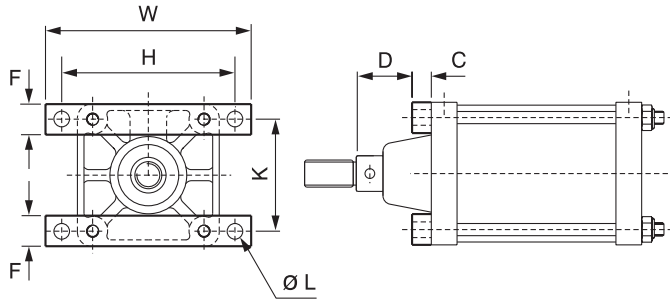

CYLINDER BORE	MTG. PART NO.	C mm	D mm	F mm	H mm	K mm	ØL mm	W mm
127 (5")	5004	19	46	38.1	171.5	108	13.5	203
152 (6")	6004	19	44	38.1	203.2	130.2	16.5	242
203 (8")	8004	25.4	4	51	266.7	168.3	20	318
254 (10")	A004	32	11	57	311.2	209.5	26	362
304 (12")	A204	32	28	63.5	384.2	246	27	448
355 (14")	A404	38	22	76.2	457.2	292	33.4	533

FRONT TRUNNION MOUNTING

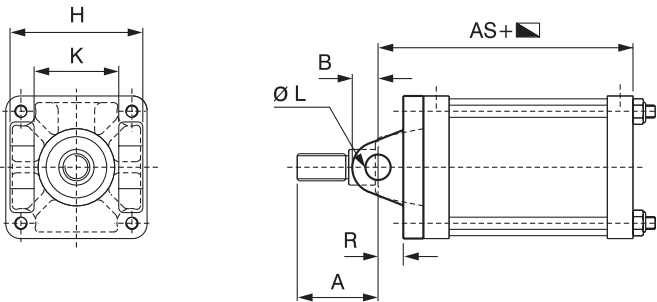

CYLINDER BORE	MTG. PART NO.	A mm	B mm	H mm	K mm	ØL mm	R mm	AS mm
127 (5")	5002	71	25	139.7	88.9	25.4	25	147
152 (6")	6002	63	25	171.5	108.0	25.4	29	172
203 (8")	8002	29	41	222.3	146.0	38.1	29	233
254 (10")	A002	56	44	269.9	165.1	38.1	32	260
304 (12")	A202	53	50.8	327	200	38.1	50.8	309
355 (14")	A402	40	57.2	381	228.6	57.2	63.5	322

DOUBLE TRUNNION WITH HINGE MOUNTING

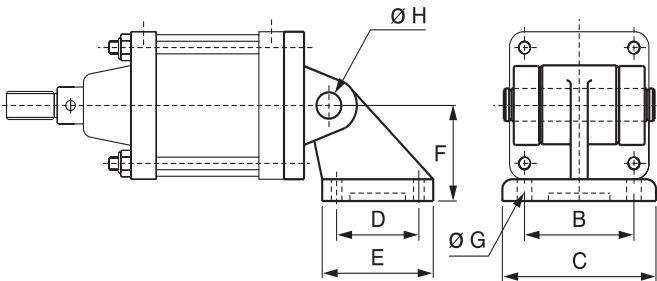

CYLINDER BORE	MTG. PART NO.	B mm	C mm	D mm	E mm	F mm	ØG mm	ØH mm
127 (5")	5008	94	124	60	90	90	14	25.4
152 (6")	6008	118	148	88	118	115	16	25.4
203 (8")	8008	122	162	90	130	135	16	38.1
254 (10")	A008	150	200	110	160	165	22	38.1
304 (12")	A208	170	230	122	182	200	27	38.1
355 (14")	A408	200	260	150	210	225	27	57.2

Material : Cast iron / Casting

ORDERING INFORMATION

CYL. TYPE	BORE SIZE	CUSHIONING / PISTON ROD MTL./SEAL MTL.	MOUNTING & FORK	STROKE IN MM
C = Inch Series	5" = 05 6" = 06 8" = 08 10" = 10 12" = 12 14" = 14	Cushioned/En8/NBR = 1 Cushioned/En8/Viton = 2 Cushioned/S.S/NBR = 3 Cushioned/S.S/Viton = 4 Non cushioned/En8/NBR = 5 Non cushioned/En8/Viton = 6 Non cushioned/S.S/NBR = 7 Non cushioned/S.S/Viton = 8	MTG. ONLY 0 = Basic 1 = Rear Trunnion 2 = Front Trunnion 3 = Rear Flange 4 = Front Flange 5 = Centre Trunnion 7 = Leg Mounting 8 = RT Mtg. with Hinge Bracket 9 = Single Trunnion	95 mm = 095 220 mm = 220 2.78 inch = 071 8 inch = 203

Typical Example : ø6" X 15" stroke cushioned cylinder with Rear trunnion mounting having S.S. piston rod and viton seals : C0641381
ø6" X 220 mm stroke cushioned cylinder with Rear trunnion mounting having S.S. piston rod and viton seals : C0641220